



# ARR Allocations to ARR Holders by Load Zone

June 3, 2002

*John Lally, ISO New England*



## Objectives

**At the completion of this presentation, you should be able to understand the process for distributing auction revenues to ARR Holders by Load Zone from the four stage ARR process.**

This presentation distributes revenues from the FTR Auction example I wrote for section 6 of Manual 06 located on [http://www.iso-ne.com/cmsmss/Standard\\_Market\\_Design/Draft\\_Manuals/Manual 06](http://www.iso-ne.com/cmsmss/Standard_Market_Design/Draft_Manuals/Manual_06)



## Agenda

- Introduction to ARR Allocations and Interim Incremental ARRs
- Introduction to the PJM Five-Bus Power System Model used in the Examples
- Overview of the Annual FTR Auction Example from Manual 6
- Review the Interim Incremental ARR Example on the assignment of FTR Auction Revenues to an Eligible Transmission Upgrade
- Review the Annual ARR Allocation Example that distributes FTR Auction Revenues to ARR Holders
- Review how Revenue Neutrality is achieved in the ARR Allocation Examples
- Review how ARR Allocations for the Annual FTR Auction are distributed to ARR Holders by Load Zone



# Understanding ARRs



## What is an ARR?

### **An Auction Revenue Right (ARR) is ...**

- Schedule 15 of the NOATT Tariff specifies that revenue collected in the FTR Auctions be allocated to *ARR holders* and *Incremental ARR holders*<sup>1</sup>.
- A right to receive FTR Auction Revenues from the sale of FTRs other than FTRs sold by FTR Holders.
- Determined and allocated to Congestion Paying Entities, Transmission Customers and NEMA LSEs (including any of the foregoing that are parties to Excepted Transactions that are included in the list of transactions in Attachments G and G-2 of the Tariff), using a four-stage process as described in this example.

<sup>1</sup> Incremental ARR holders are entities who pay for new transmission upgrades which increase transfer capability on the NEPOOL Transmission System, making it possible for the System Operator to award additional FTRs in the FTR Auction, shall be awarded ARRs.



## How are ARRs obtained?

### **ARRs are obtained by an allocation ...**

- Every entity with load that is responsible for making congestion payments receives an ARR that represents a load weighted ratio share of all capacity sources delivered to their load sink.
- Participant rights to the auction revenues are assured in the four-stage ARR Allocation by ensuring that injections and withdrawals that result from ARRs awarded in the allocation will not overload the NEPOOL Transmission System under normal conditions.



# The Five Bus Power System Model

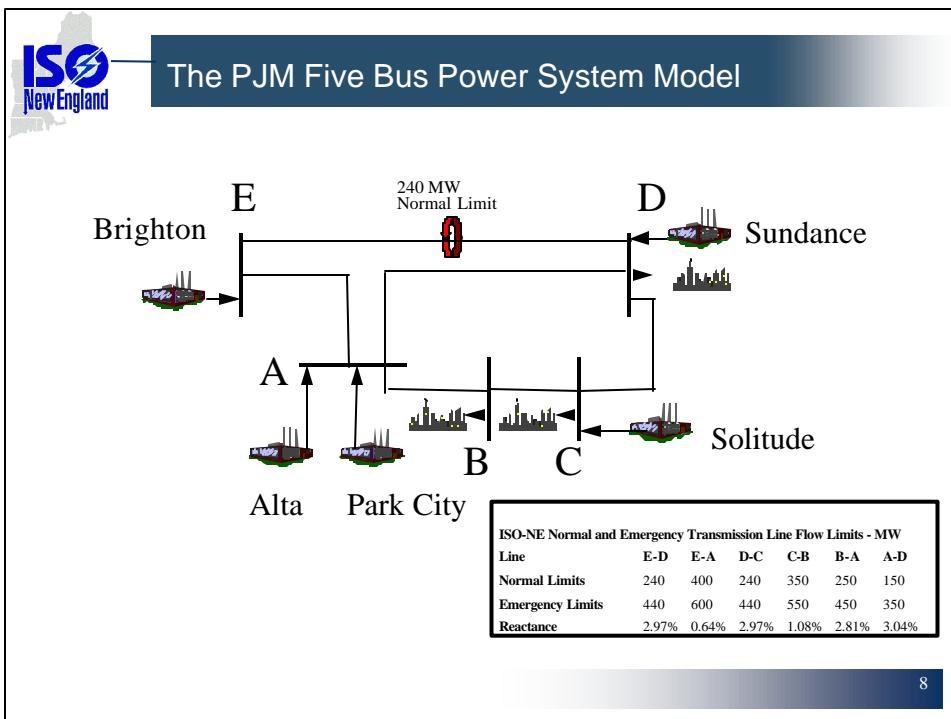



## Five Bus ARR Model with Load & Generation

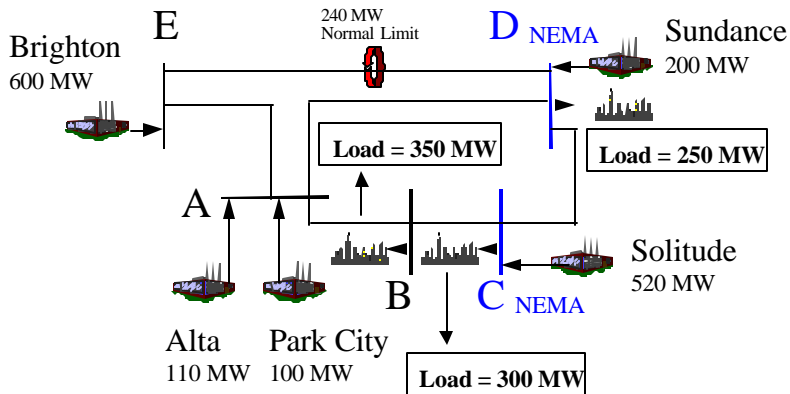

ISO-NE Normal and Emergency Transmission Line Flow Limits - MW						
Line	E-D	E-A	D-C	C-B	B-A	A-D
Normal Limits	240	400	240	350	250	150
Emergency Limits	440	600	440	550	450	350
Reactance	2.97%	0.64%	2.97%	1.08%	2.81%	3.04%



## Five Bus ARR Model with ET & NEMA Contracts

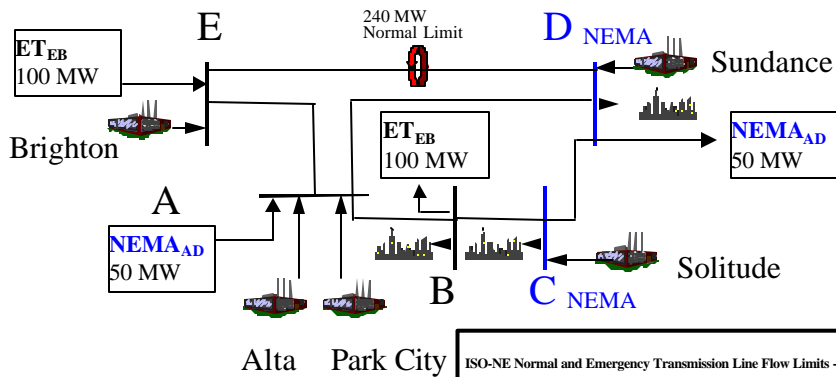

ISO-NE Normal and Emergency Transmission Line Flow Limits - MW						
Line	E-D	E-A	D-C	C-B	B-A	A-D
Normal Limits	240	400	240	350	250	150
Emergency Limits	440	600	440	550	450	350
Reactance	2.97%	0.64%	2.97%	1.08%	2.81%	3.04%



# Annual FTR Auction Example

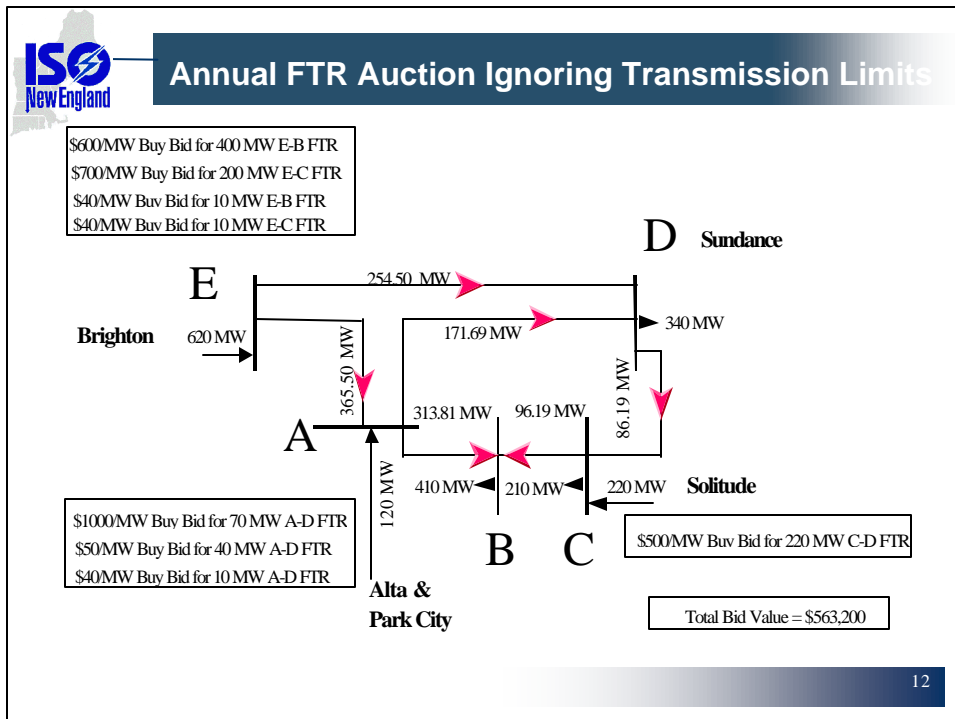



## Annual FTR Auction Respecting Transmission Limits

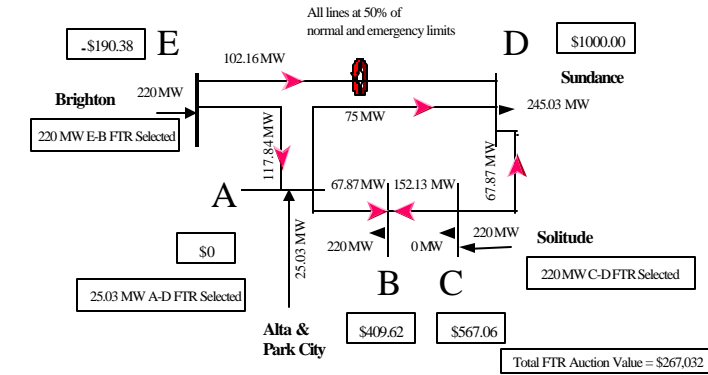

Transmission Line	Pre-Contingency Line Flows with All Lines In-Service	50% of Normal Limits	Post-Contingency Line Flows after Loss of Indicated Line						50% of Emergency Limits
			E-D	E-A	D-C	C-B	B-A	A-D	
E-D	102.16	120	0.00	220.00	133.19	32.62	133.19	151.30	220
E-A	117.84	200	220.00	0.00	86.81	187.38	86.81	68.70	300
D-C	-67.87	120	-99.24	-31.69	0.00	-220.00	0.00	-93.73	220
C-B	152.13	175	120.76	188.31	220.00	0.00	220.00	126.27	275
B-A	-67.87	125	-99.24	-31.69	0.00	-220.00	0.00	-93.73	225
A-D	75.00	75	145.79	-6.65	111.84	-7.58	111.84	0.00	175



## Annual FTR Auction Results

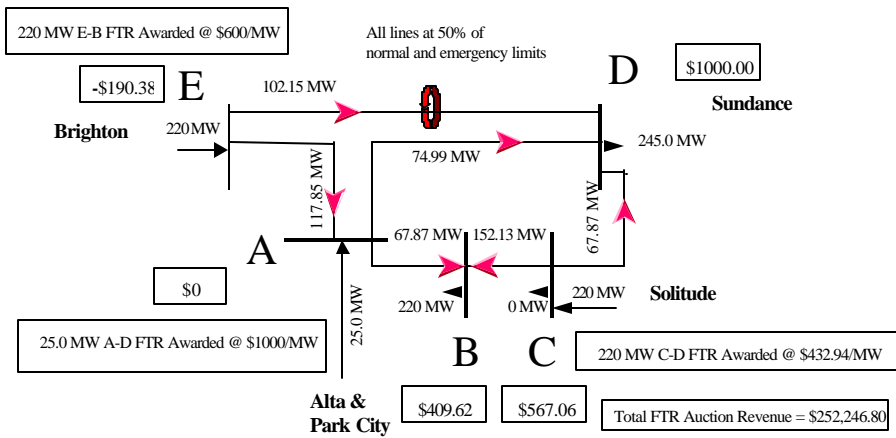



# Interim Incremental ARR Allocation of Annual FTR Auction Revenues



## The Five Bus Model - Pre Line E-A Upgrade

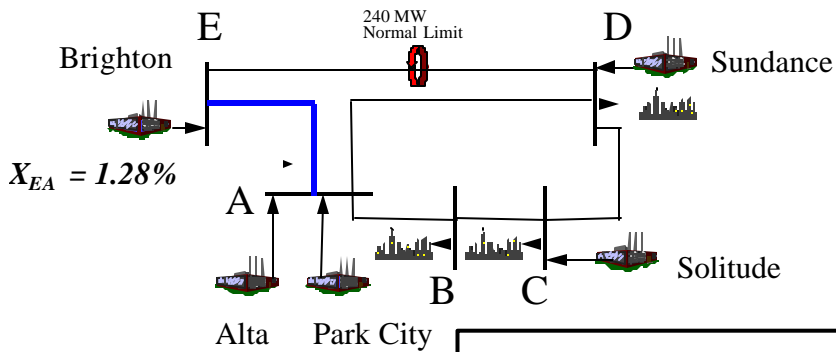

ISO-NE Normal and Emergency Transmission Line Flow Limits - MW						
Line	E-D	E-A	D-C	C-B	B-A	A-D
Normal Limits	240	200	240	350	250	150
Emergency Limits	440	300	440	550	450	350
Reactance	2.97%	1.28%	2.97%	1.08%	2.81%	3.04%



## Annual FTR Auction Results without Line E-A Upgrade

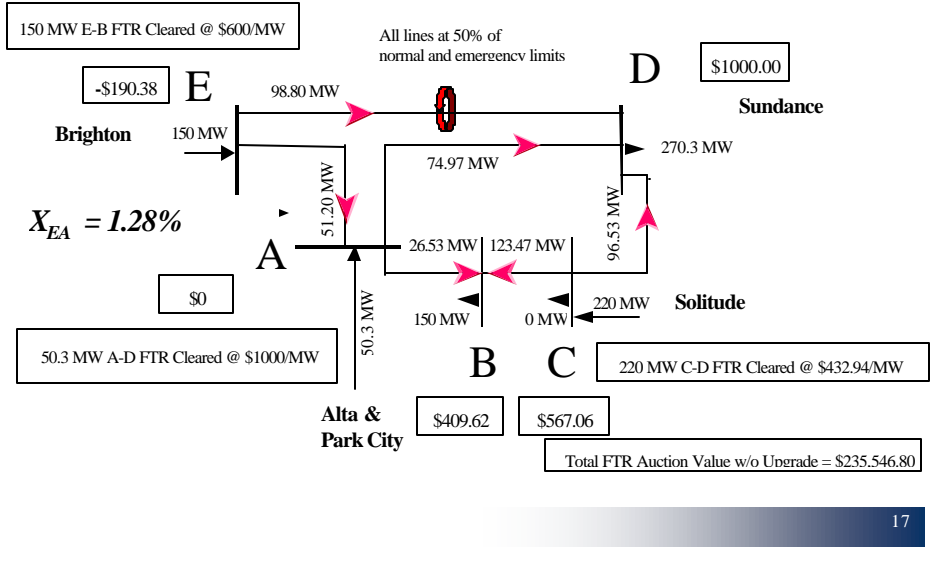

## Interim Incremental ARR Payment

The Interim Incremental ARR payment is the difference in value between the Annual FTR Auction results with and without the eligible transmission upgrade:

	Annual FTR Auction \$
With Upgrade	252,246.80
Without Upgrade	235,546.80
Total IIARR Payment	16,700.00

The IIARR would be settled at a monthly rate for the duration of the effective period of the FTR Auction (i.e.  $16,700 / 12 = 1,391.67$  month).



## Annual ARR Allocation Example



### Collection and Disbursal of FTR Auction Revenues

In the Annual FTR Auction Example, the total revenue resulting from the FTR Auction was \$252,246.80. Interim Incremental ARR's were allocated \$16,700.00 of this sum, leaving \$235,546.80 to distribute through the ARR process.

The following Annual ARR Allocation Example will demonstrate how one-twelfth of the revenue from the annual example will be collected and disbursed on a monthly basis.



## Stage 1 ARR

ARRs are allocated in two steps in the first stage of the ARR Allocation ...

- Excepted Transactions are assigned ARRs from a capacity source to a load sink
- The remaining capacity sources and load sinks are assigned as ARRs in proportion to capacity and load



## Five Bus ARR Model with Load & Generation

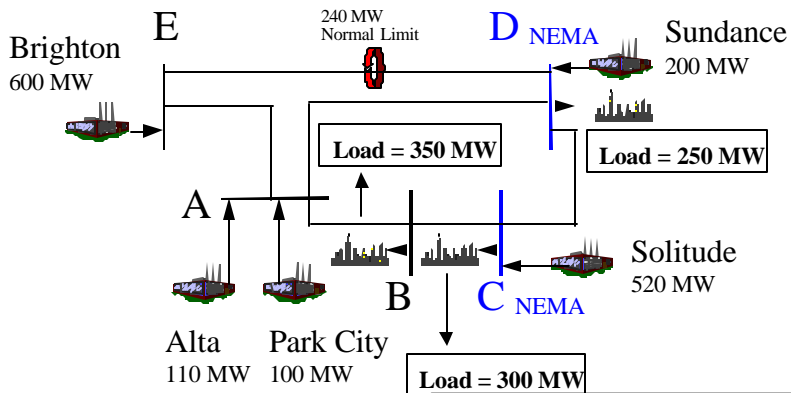

ISO-NE Normal and Emergency Transmission Line Flow Limits - MW						
Line	E-D	E-A	D-C	C-B	B-A	A-D
Normal Limits	240	400	240	350	250	150
Emergency Limits	440	600	440	550	450	350
Reactance	2.97%	0.64%	2.97%	1.08%	2.81%	3.04%



## Stage 1 ARRs - Excepted Transactions

This example assumes that there is a 100 MW Excepted Transaction between Brighton at Node E and the load sink at Node B.

- The entity responsible for paying the congestion costs associated with energy purchased under this Excepted Transaction would be allocated Stage 1 ARRs that correspond to this transaction.
  - 100 MW of Stage 1 ARRs would be initially allocated from Node E to Node B.



## Five Bus ARR Model with Excepted Transaction

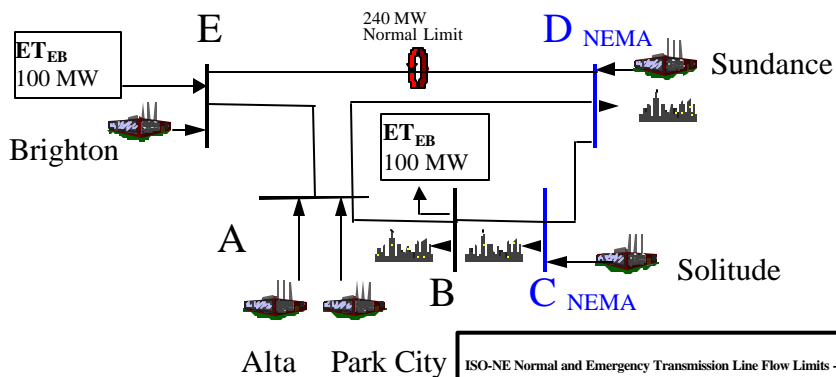

ISO-NE Normal and Emergency Transmission Line Flow Limits - MW						
Line	E-D	E-A	D-C	C-B	B-A	A-D
Normal Limits	240	400	240	350	250	150
Emergency Limits	440	600	440	550	450	350
Reactance	2.97%	0.64%	2.97%	1.08%	2.81%	3.04%



## Stage 1 ARR - Load Ratio ARRs

Stage 1 ARRs would also be allocated from each generator (net of capacity allocated to Excepted Transactions) to each load in proportion to Monthly Peak Load (net of load met by Excepted Transactions). The amount of ARRs allocated from each source will be equal to total generating capacity at that node.

- For example, since Alta has a capacity of 110 MW, a total of 110 MW of ARRs will be allocated from Node A.
- Since there is a total of 1530 MW of capacity on this five-bus network, less 100 MW delivered under Excepted Transactions, a total of 1430 MW of Load Ratio ARRs will be allocated in this step.
- Other capacity sources, such as tie lines to other control areas, would also count as “generators” for the purposes of defining Stage 1 ARRs.

25



## Five Bus ARR Model with ET, Load & Generation

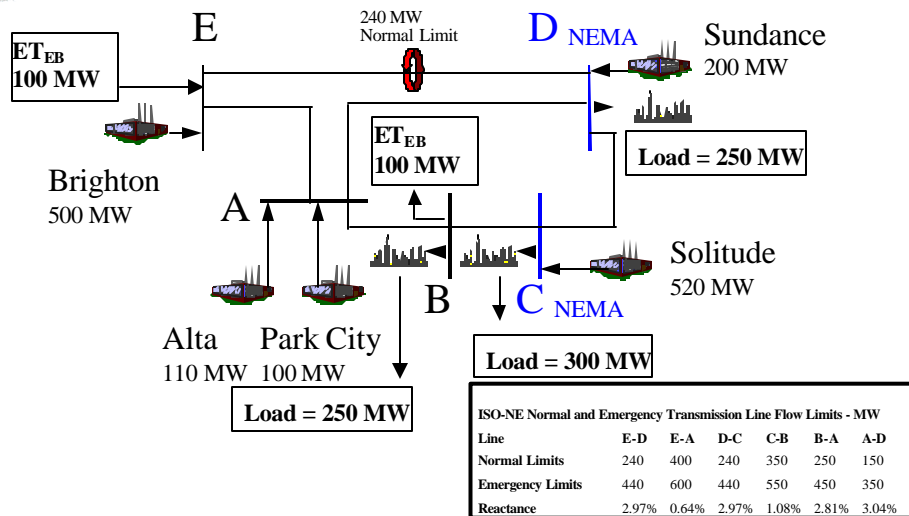

26



## Stage 1 ARR - Load Ratio Determination

Stage 1 ARRs are allocated among the entities that are responsible for paying the congestion costs associated with serving load, in proportion to the load's share of the NEPOOL Monthly Peak Load.

- Each load's share of the NEPOOL Monthly Peak Load, which is 800 MW (after deducting 100 MW of Monthly Peak Load served by Excepted Transactions) is calculated in the table below.
- Since load at Node B constitutes 31.25% of the NEPOOL Monthly Peak Load, the entities responsible for paying congestion costs associated with serving load in Node B will receive 31.25% of the ARRs from each generator location to Node B.

Load Location	Peak Load MW	Peak Load Distribution
Node B	250	31.25%
Node C	300	37.50%
Node D	250	31.25%

27



## Stage 1 ARR - Initial Allocation

The table below indicates the Stage 1 allocation of ARRs from each generator to load. The "ET" notation indicates that those ARRs were allocated in association with an Excepted Transaction.

Source Location	Sink Location	Load Name	Peak Load Distribution	Capacity (MW)	Initial ARRs (MW)
A	B	Node B	31.25%	210	65.625
A	C	Node C	37.50%	210	78.75
A	D	Node D	31.25%	210	65.625
C	B	Node B	31.25%	520	162.5
C	C	Node C	37.50%	520	195
C	D	Node D	31.25%	520	162.5
D	B	Node B	31.25%	200	62.5
D	C	Node C	37.50%	200	75
D	D	Node D	31.25%	200	62.5
E	B	Node B ("ET")	NA	100	100
E	B	Node B	31.25%	500	156.25
E	C	Node C	37.50%	500	187.5
E	D	Node D	31.25%	500	156.25

28



## Stage 1 Line Flows Compared with Limits - MW

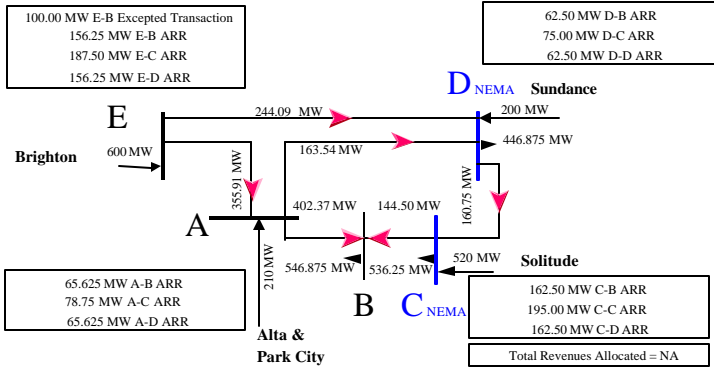

Transmission Line	Pre-Contingency Line Flows with All Lines In-Service	100% of Normal Limits	Post-Contingency Line Flows after Loss of Indicated Line						100% of Emergency Limits
			E-D	E-A	D-C	C-B	B-A	A-D	
E-D	244.09	240	0.00	600.00	170.60	178.03	428.03	351.24	440
E-A	355.91	400	600.00	0.00	429.40	421.97	171.97	248.76	600
D-C	160.75	240	85.80	270.04	0.00	16.25	563.12	104.37	440
C-B	144.50	350	69.55	253.79	-16.25	0.00	546.87	88.12	550
B-A	-402.37	250	-477.32	-293.08	-563.12	-546.87	0.00	-458.76	450
A-D	163.54	150	332.68	-83.08	76.27	85.09	381.97	0.00	350

29



## Stage 2 Line Flows with all Initial ARR

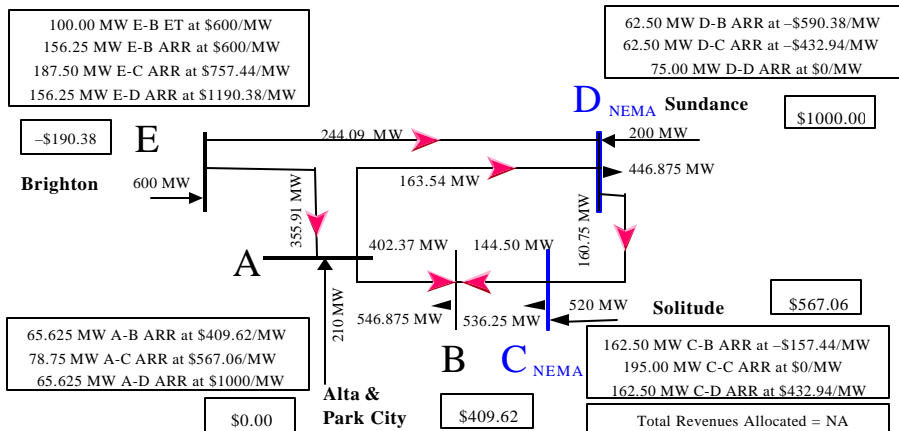

30



## Stage 2 Positive ARR Line Flows Compared with Limits - MW

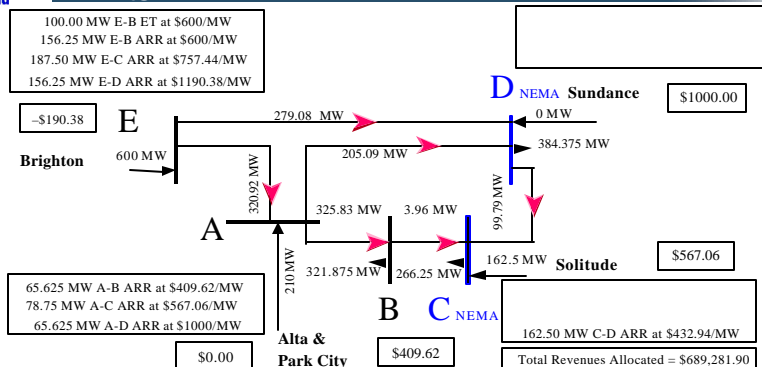

Transmission Line	Pre-Contingency Line Flows with All Lines In-Service	100% of Normal Limits	Post-Contingency Line Flows after Loss of Indicated Line						100% of Emergency Limits
			E-D	E-A	D-C	C-B	B-A	A-D	
E-D	279.08	240	0.00	600.00	233.46	280.89	428.03	413.45	440
E-A	320.92	400	600.00	0.00	366.54	319.11	171.97	186.55	600
D-C	99.79	240	14.10	198.34	0.00	103.75	425.62	29.08	440
C-B	-3.96	350	-89.65	94.59	-103.75	0.00	321.87	-74.67	550
B-A	-325.83	250	-411.53	-227.29	-425.62	-321.88	0.00	-396.55	450
A-D	205.09	150	398.47	-17.29	150.92	207.24	381.97	0.00	350

31



## Stage 2 Line Flows Compared with Limits - MW & %

Transmission Line	Pre-Contingency Line Flows with All Lines In-Service	100% of Normal Limits	Post-Contingency Line Flows after Loss of Indicated Line						100% of Emergency Limits
			E-D	E-A	D-C	C-B	B-A	A-D	
E-D	279.08	240	0.00	600.00	233.46	280.89	428.03	413.45	440
E-A	320.92	400	600.00	0.00	366.54	319.11	171.97	186.55	600
D-C	99.79	240	14.10	198.34	0.00	103.75	425.62	29.08	440
C-B	-3.96	350	-89.65	94.59	-103.75	0.00	321.87	-74.67	550
B-A	-325.83	250	-411.53	-227.29	-425.62	-321.88	0.00	-396.55	450
A-D	205.09	150	398.47	-17.29	150.92	207.24	381.97	0.00	350

Transmission Line	Pre-Contingency Line Flows with All Lines In-Service	100% of Normal Limits	Post-Contingency Line Flows after Loss of Indicated Line						100% of Emergency Limits
			E-D	E-A	D-C	C-B	B-A	A-D	
E-D	116.3%	240	0.0%	136.4%	53.1%	63.8%	97.3%	94.0%	440
E-A	80.2%	400	100.0%	0.0%	61.1%	53.2%	28.7%	31.1%	600
D-C	41.6%	240	3.2%	45.1%	0.0%	23.6%	96.7%	6.6%	440
C-B	1.1%	350	16.3%	17.2%	18.9%	0.0%	58.5%	13.6%	550
B-A	130.3%	250	91.5%	50.5%	94.6%	71.5%	0.0%	88.1%	450
A-D	136.7%	150	113.8%	4.9%	43.1%	59.2%	109.1%	0.0%	350

32



## Stage 2 ARR Scaling to Achieve Simultaneously Feasibility

1	2	3	4	5 = 3 * 4	6	7 = 5 * 6	8 = 4 * 7
Type	ARR Path	Initial ARRs (MW)	Line A-D Sensitivity Factors <sup>1</sup>	Flow on Constrained Line A-D (MW)	Scale Reduction Factor	Stage 2 ARRs (MW)	Flow on Constrained Line A-D (MW)
ARR	A-B	65.625	0.1792	11.76	0.73139	47.997	8.60
ARR	A-C	78.75	0.2481	19.54	0.73139	57.597	14.29
ARR	A-D	65.625	0.4376	28.72	0.73139	47.997	21.00
ARR	C-D	162.5	0.1895	30.79	0.73139	118.850	22.52
ET	E-B	100	0.1017	10.17	0.73139	73.139	7.44
ARR	E-B	156.25	0.1017	15.89	0.73139	114.279	11.62
ARR	E-C	187.5	0.1706	31.98	0.73139	137.135	23.39
ARR	E-D	156.25	0.3600	56.25	0.73139	114.279	41.14
				205.09			150.00

<sup>1</sup> Sensitivity factors for line A-D are for all lines in-service.

$$\text{Scale Reduction Factor} = (\text{Flow Limit on Line A-D}) / (\text{Flow on Line A-D}) = 150 / 205.09 = 0.73139$$

33



## Stage 2 Line Flows Compared with Limits - MW

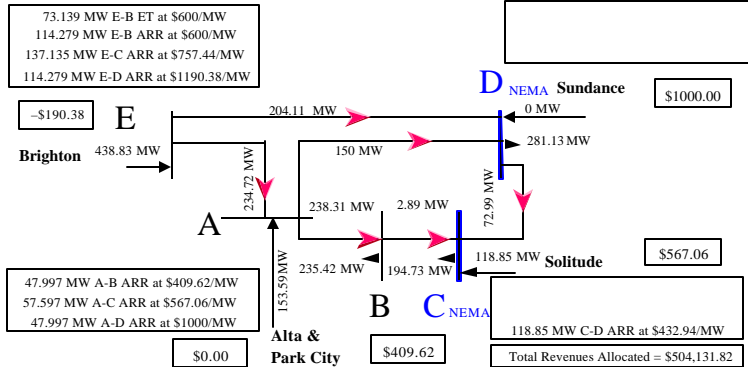

Transmission Line	Pre-Contingency Line Flows with All Lines In-Service	100% of Normal Limits	Post-Contingency Line Flows after Loss of Indicated Line					100% of Emergency Limits	
			E-D	E-A	D-C	C-B	B-A		A-D
E-D	204.11	240	0.00	438.83	170.75	205.44	313.06	302.40	440
E-A	234.72	400	438.83	0.00	268.08	233.39	125.78	136.44	600
D-C	72.99	240	10.31	145.06	0.00	75.88	311.30	21.27	440
C-B	-2.89	350	-65.57	69.18	-75.88	0.00	235.42	-54.61	550
B-A	-238.31	250	-300.99	-166.23	-311.30	-235.42	0.00	-290.03	450
A-D	150.00	150	291.44	-12.64	110.38	151.57	279.37	0.00	350

34



## Stage 3 NEMA ARRs - NEMA Contract Treatment

**In Stage 3, ARR are allocated to NEMA load serving entities (LSEs) with qualifying long-term purchase contracts.**

- This reallocation of ARR among NEMA LSEs is not to affect the allocation of ARR in Stage 2 to entities that are not NEMA LSEs.
- The ARR that correspond to these purchase contracts will be reduced if necessary to ensure simultaneous feasibility.
- No other NEMA ARR are included in this power flow, so the ARR that correspond to these purchase contracts will only be reduced if necessary to ensure simultaneous feasibility, even if no other NEMA LSE's were awarded any ARR.

**Then in Stage 4, ARR for the remaining NEMA LSEs' loads are taken into account, and reduced as necessary to maintain simultaneous feasibility.**

35



## Stage 3 Line Flows Compared with Limits - MW

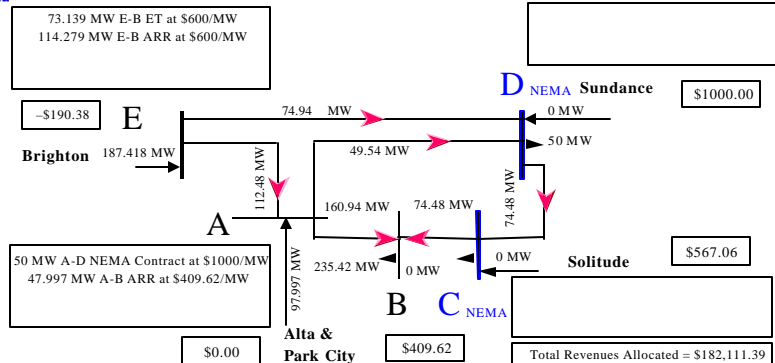

Transmission Line	Pre-Contingency Line Flows with All Lines In-Service	100% of Normal Limits	Post-Contingency Line Flows after Loss of Indicated Line						100% of Emergency Limits
			E-D	E-A	D-C	C-B	B-A	A-D	
E-D	74.94	240	0.00	187.42	40.89	40.89	148.51	107.40	440
E-A	112.48	400	187.42	0.00	146.52	146.52	38.91	80.02	600
D-C	74.48	240	51.47	109.02	0.00	0.00	235.42	57.40	440
C-B	74.48	350	51.47	109.02	0.00	0.00	235.42	57.40	550
B-A	-160.94	250	-183.95	-126.40	-235.42	-235.42	0.00	-178.02	450
A-D	49.54	150	101.47	-28.40	9.11	9.11	136.90	0.00	350

36



## Stage 4 Initial ARR Scaling to test for Feasibility

1	2	3	4	5	6 = 3 * 5	8 = 4 * 6
Type	ARR Path	Initial ARRs (MW)	Line A-D Sensitivity Factors <sup>1</sup>	Scale Reduction Factor	Stage 4 ARRs (MW)	Flow on Constrained Line A-D (MW)
ARR	A-B	47.997	0.1792	1	47.997	8.60
ARR	A-C	57.597	0.2481	1	57.597	14.29
ARR	A-D	47.997	0.4376	0.8	38.398	16.80
NEMA	A-D	50	0.4376	1	50.000	21.88
ARR	C-D	118.850	0.1895	0.8	95.080	18.01
ET	E-B	73.139	0.1017	1	73.139	7.44
ARR	E-B	114.279	0.1017	1	114.279	11.62
ARR	E-C	137.135	0.1706	1	137.135	23.39
ARR	E-D	114.279	0.3600	0.8	91.423	32.91
						154.95

<sup>1</sup> Sensitivity factors for line A-D are for all lines in-service.

Scale Reduction Factor for NEMA ARRs at a load location affected by a NEMA Contract:  
 $[ 1 - (\text{NEMA Contract} / \text{Nodal Load}) ] = [ 1 - ( 50 / 250 ) ] = 0.8$

37



## Stage 4 Line Flows Compared with Limits - MW

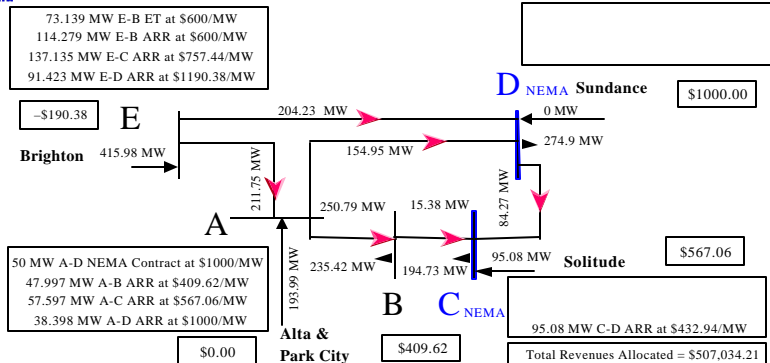

Transmission Line	Pre-Contingency Line Flows with All Lines In-Service	100% of Normal Limits	Post-Contingency Line Flows after Loss of Indicated Line					100% of Emergency Limits	
			E-D	E-A	D-C	C-B	B-A		A-D
E-D	204.23	240	0.00	415.98	165.70	211.26	318.88	305.75	440
E-A	211.75	400	415.98	0.00	250.27	204.72	97.10	110.23	600
D-C	84.27	240	21.56	149.30	0.00	99.65	335.07	30.85	440
C-B	-15.38	350	-78.09	49.64	-99.65	0.00	235.42	-68.80	550
B-A	-250.79	250	-313.50	-185.77	-335.07	-235.42	0.00	-304.22	450
A-D	154.95	150	296.46	8.22	109.20	163.29	291.09	0.00	350

38



## Stage 4 Line Flows Compared with Limits - MW & %

Transmission Line	Pre-Contingency Line Flows with All Lines In-Service	100% of Normal Limits	Post-Contingency Line Flows after Loss of Indicated Line						100% of Emergency Limits
			E-D	E-A	D-C	C-B	B-A	A-D	
E-D	204.23	240	0.00	415.98	165.70	211.26	318.88	305.75	440
E-A	211.75	400	415.98	0.00	250.27	204.72	97.10	110.23	600
D-C	84.27	240	21.56	149.30	0.00	99.65	335.07	30.85	440
C-B	-15.38	350	-78.09	49.64	-99.65	0.00	235.42	-68.80	550
B-A	-250.79	250	-313.50	-185.77	-335.07	-235.42	0.00	-304.22	450
A-D	154.95	150	296.46	8.22	109.20	163.29	291.09	0.00	350

Transmission Line	Pre-Contingency Line Flows with All Lines In-Service	100% of Normal Limits	Post-Contingency Line Flows after Loss of Indicated Line						100% of Emergency Limits
			E-D	E-A	D-C	C-B	B-A	A-D	
E-D	85.1%	240	0.0%	94.5%	37.7%	48.0%	72.5%	69.5%	440
E-A	52.9%	400	69.3%	0.0%	41.7%	34.1%	16.2%	18.4%	600
D-C	35.1%	240	4.9%	33.9%	0.0%	22.6%	76.2%	7.0%	440
C-B	4.4%	350	14.2%	9.0%	18.1%	0.0%	42.8%	12.5%	550
B-A	100.3%	250	69.7%	41.3%	74.5%	52.3%	0.0%	67.6%	450
A-D	103.3%	150	84.7%	2.3%	31.2%	46.7%	83.2%	0.0%	350

39



## Stage 4 ARR Scaling to test for Simultaneous Feasibility

1	2	3	4	5 = 3 * 4	6	7	8 = 3 * 7	9 = 4 * 8
Type	ARR Path	Initial Stage 4 ARRs (MW)	Line A-D Sensitivity Factors <sup>1</sup>	Flow on Constrained Line A-D (MW)	NEMA ARRs Subject to Reduction (MW)	Scale Reduction Factor	Stage 2 ARRs (MW)	Flow on Constrained Line A-D (MW)
ARR	A-B	47.997	0.1792	8.60		1	47.997	8.60
ARR	A-C	57.597	0.2481	14.29	14.29	0.95307	54.894	13.62
ARR	A-D	38.398	0.4376	16.80	16.80	0.95307	36.596	16.01
NEMA	A-D	50	0.4376	21.88		1	50.000	21.88
ARR	C-D	95.080	0.1895	18.01	18.01	0.95307	90.618	17.17
ET	E-B	73.139	0.1017	7.44		1	73.139	7.44
ARR	E-B	114.279	0.1017	11.62		1	114.279	11.62
ARR	E-C	137.135	0.1706	23.39	23.39	0.95307	130.699	22.29
ARR	E-D	91.423	0.3600	32.91	32.91	0.95307	87.133	31.37
				154.95	105.41			150.00

<sup>1</sup> Sensitivity factors for line A-D are for all lines in-service.

Scale Reduction Factor for NEMA ARRs subject to reduction:  
 $[ 1 - ( \text{Total Flow on Constrained Line} - \text{Line Limit} ) / \text{NEMA ARRs subject to reduction} ] =$   
 $[ 1 - ( 154.95 - 150 ) / 105.41 ] = 0.95307$

40



## Stage 4 Line Flows Compared with Limits - MW

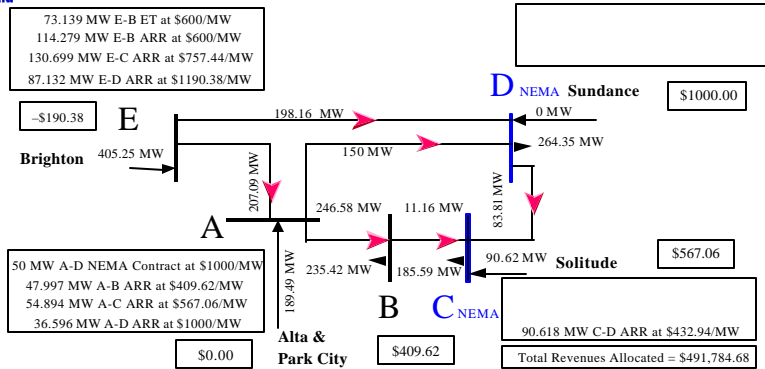

Transmission Line	Pre-Contingency Line Flows with All Lines In-Service	100% of Normal Limits	Post-Contingency Line Flows after Loss of Indicated Line						100% of Emergency Limits
			E-D	E-A	D-C	C-B	B-A	A-D	
E-D	198.16	240	0.00	405.25	159.85	203.26	310.88	296.44	440
E-A	207.09	400	405.25	0.00	245.40	201.99	94.37	108.81	600
D-C	83.81	240	22.97	147.41	0.00	94.97	330.39	32.10	440
C-B	-11.16	350	-72.01	52.43	-94.97	0.00	235.42	-62.88	550
B-A	-246.58	250	-307.42	-182.98	-330.39	-235.42	0.00	-298.29	450
A-D	150.00	150	287.31	6.50	104.50	156.06	283.86	0.00	350

41



## Revenue Neutrality Adjustment to the Annual ARR Allocation Example



## First Month's Allocation of Annual FTR Revenues

Type	ARR Path	Stage 4 ARR's MW	FTR Path Clearing Price \$/MW	Stage 4 ARR Allocation Calculation	Monthly Scale Factor <sup>1</sup>	Monthly Stage 4 ARR Settlement Allocation
ARR	A-B	47.997	409.62	\$19,660.63	0.03991	\$784.73
ARR	A-C	54.894	567.06	\$31,127.91	0.03991	\$1,242.43
ARR	A-D	36.596	1000.00	\$36,595.67	0.03991	\$1,460.67
NEMA	A-D	50.000	1000.00	\$50,000.00	0.03991	\$1,995.68
ARR	C-D	90.618	432.94	\$39,232.10	0.03991	\$1,565.90
ET	E-B	73.139	600.00	\$43,883.19	0.03991	\$1,751.54
ARR	E-B	114.279	600.00	\$68,567.48	0.03991	\$2,736.78
ARR	E-C	130.699	757.44	\$98,996.53	0.03991	\$3,951.31
ARR	E-D	87.133	1190.38	\$103,720.85	0.03991	\$4,139.88
				\$491,784.37		\$19,628.90

<sup>1</sup> The monthly scale factor is one-twelfth of the Annual FTR Auction revenues divided by the Stage 4 ARR Allocation less any Interim Incremental ARRs (i.e.  $(\$252,246.80 - \$16,700.00) / 12 = 19,628.90$  and  $19,628.90 / 491,784.37 = 0.039914$ ).



## Distribution of the Annual ARR Allocation to ARR Holders by Load Zone



## First Month's Allocation of Annual FTR Revenues to Excepted Transactions, NEMA Contracts & Nodes

Type	ARR Path	Monthly Stage 4 ARR Settlement Allocation	1st Month's ET ARR Settlement Allocation to Node B	1st Month's NEMA ARR Settlement Allocation to Node D	1st Month's Node B Settlement Allocation	1st Month's Node C Settlement Allocation	1st Month's Node D Settlement Allocation
ARR	A-B	\$784.73			\$784.73		
ARR	A-C	\$1,242.43				\$1,242.43	
ARR	A-D	\$1,460.67					\$1,460.67
NEMA	A-D	\$1,995.68		\$1,995.68			
ARR	C-D	\$1,565.90					\$1,565.90
ET	E-B	\$1,751.54	\$1,751.54				
ARR	E-B	\$2,736.78			\$2,736.78		
ARR	E-C	\$3,951.31				\$3,951.31	
ARR	E-D	\$4,139.88					\$4,139.88
		\$19,628.90	\$1,751.54	\$1,995.68	\$3,521.50	\$5,193.74	\$7,166.44



## First Month's Allocation of Annual FTR Revenues to Excepted Transactions, NEMA Contracts & Zones

Type	ARR Path	Monthly Stage 4 ARR Settlement Allocation	1st Month's ET ARR Settlement Allocation	1st Month's NEMA ARR Settlement Allocation	1st Month's NE Zone Settlement Allocation	1st Month's NEMA Zone Settlement Allocation
ARR	A-B	\$784.73			\$784.73	
ARR	A-C	\$1,242.43				\$1,242.43
ARR	A-D	\$1,460.67				\$1,460.67
NEMA	A-D	\$1,995.68		\$1,995.68		
ARR	C-D	\$1,565.90				\$1,565.90
ET	E-B	\$1,751.54	\$1,751.54			
ARR	E-B	\$2,736.78			\$2,736.78	
ARR	E-C	\$3,951.31				\$3,951.31
ARR	E-D	\$4,139.88				\$4,139.88
		\$19,628.90	\$1,751.54	\$1,995.68	\$3,521.50	\$12,360.18

Note that for the purposes of this example the NE Zone is defined as Node B and the NEMA Zone is defined as Nodes C and D.



## Allocation of Participant Monthly Peak RTALO to Zones

Participant	Monthly Peak RTALO (MW)	NE Load Zone (% Load)	NEMA Load Zone (% Load)	NE Load Zone (MW)	NEMA Load Zone (MW)
Concord Electric	50	0%	100%	0	50
Boston Electric	200	50%	50%	100	100
Providence Electric	60	55%	45%	33	27
Augusta Electric	100	100%	0%	100	0
New York Electric	300	25%	75%	75	225
Montpelier Electric	40	30%	70%	12	28
Hartford Electric	150	20%	80%	30	120
<b>Total</b>	<b>900</b>			<b>350</b>	<b>550</b>

Note that ARRs associated with the load share of generation and tie sources are accumulated by load zone. Auction revenues are awarded based on the share of the Real Time Adjusted Load Obligation (RTALO) of each Transmission Customer and Congestion Paying Entity in the Load Zone.

47



## Determination of Participant Load Share Percentages by Zone Adjusted for ETs and NEMA Contracts

Participant	NE Load Zone RTALO (MW)	NEMA Load Zone RTALO (MW)	NE Load Zone ET ARR (MW)	NEMA ARR (MW)	Adjusted NE Load Zone (MW)	Adjusted NEMA Load Zone (MW)	Adjusted NE Load Zone (% Load Zone)	Adjusted NEMA Load Zone (% Load Zone)
Concord Electric	0	50		50	0	0	0.0%	0.0%
Boston Electric	100	100			100	100	36.1%	20.0%
Providence Electric	33	27			33	27	11.9%	5.4%
Augusta Electric	100	0	73.139		26.861	0	9.7%	0.0%
New York Electric	75	225			75	225	27.1%	45.0%
Montpelier Electric	12	28			12	28	4.3%	5.6%
Hartford Electric	30	120			30	120	10.8%	24.0%
	<b>350</b>	<b>550</b>	<b>73.139</b>	<b>50</b>	<b>276.861</b>	<b>500</b>	<b>100.0%</b>	<b>100.0%</b>

Note that RTALO stands for the Real Time Adjusted Load Obligation at the the time of the NEPOOL Monthly Peak.

48



## Distribution of Load Share ARR by Monthly Peak RTALO to Participants by Zone

Participant	Adjusted NE Load Zone (% Load Zone)	Adjusted NEMA Load Zone (% Load Zone)	1st Month's NE Zone Settlement Allocation	1st Month's NEMA Zone Settlement Allocation
Concord Electric	0.0%	0.0%	\$0.00	\$0.00
Boston Electric	36.1%	20.0%	\$1,271.94	\$2,472.04
Providence Electric	11.9%	5.4%	\$419.74	\$667.45
Augusta Electric	9.7%	0.0%	\$341.66	\$0.00
New York Electric	27.1%	45.0%	\$953.95	\$5,562.08
Montpelier Electric	4.3%	5.6%	\$152.63	\$692.17
Hartford Electric	10.8%	24.0%	\$381.58	\$2,966.44
	100.0%	100.0%	\$3,521.50	\$12,360.18

Note that RTALO stands for the Real Time Adjusted Load Obligation at the the time of the NEPOOL Monthly Peak.



## First Month's Annual ARR Allocation to Participants

Participant	1st Month's ET ARR Settlement Allocation	1st Month's NEMA ARR Settlement Allocation	1st Month's NE Zone Settlement Allocation	1st Month's NEMA Zone Settlement Allocation	Participant's 1st Month's ARR Settlement
Concord Electric		\$1,995.68	\$0.00	\$0.00	\$1,995.68
Boston Electric			\$1,271.94	\$2,472.04	\$3,743.97
Providence Electric			\$419.74	\$667.45	\$1,087.19
Augusta Electric	\$1,751.54		\$341.66	\$0.00	\$2,093.20
New York Electric			\$953.95	\$5,562.08	\$6,516.03
Montpelier Electric			\$152.63	\$692.17	\$844.80
Hartford Electric			\$381.58	\$2,966.44	\$3,348.02
Total	\$1,751.54	\$1,995.68	\$3,521.50	\$12,360.18	\$19,628.90



## Acknowledgements

To Dr. N. S. Rau for his tutelage in optimization theory.

To the PJM Interconnection for the five-bus power system model upon which this example is based.

To LECG for their initial contributions to the ARR market design.



?

## Questions?