

Reliability Analyses in Resource Adequacy Assessments “All Possible Paths” Addendum

Wayne Coste

Principal Engineer, Resource Adequacy

April 12, 2010

Supporting Analysis to Evaluate Individual Tie Line Contributions

- Probabilistic analysis
 - Four control areas modeled: HQ, MT, NE and NY
 - Assumptions/data for all control areas are consistent with those for the tie benefit study for 2010 ARA3.
 - Inter-Area transmission constraints are modeled, while internal constraints within each Area are relaxed
 - The internal transmission constraints were not modeled to save simulation time. These methodologies can be applied with internal transmission constraints modeled.
 - All control areas are assumed “at criterion” conditions
 - Bring every area (interconnected) to .1 days/year simultaneously

Supporting Analysis to Evaluate Individual Tie Line Contributions

- The following individual tie(s) are used for tie benefit evaluation:
 - HQ Phase II
 - Maritimes
 - NY AC ties
 - NY DC tie
- A total of 16 interconnection states for four connections
 - Number of states equals n^2 for 'n' individual ties

HQ-Phase II Tie Benefit Evaluation

Scenario	Discription	Interconnection Status					LOLE	
		HQ-Phase II	Maritimes	NY-AC	NY-DC	LOLE		
1	Cut None	✓	✓	✓	✓	0.100		
2	Cut All	✗	✗	✗	✗	0.313	A	
3	Cut HQ-Phase II	✗	✓	✓	✓	0.171		
4	Cut Maritimes	✓	✗	✓	✓	0.141		
5	Cut NY-AC	✓	✓	✗	✓	0.104		
6	Cut NY-DC	✓	✓	✓	✗	0.101	E	
7	Cut HQ-Phase II & Maritimes	✗	✗	✓	✓	0.224	C	
8	Cut HQ-Phase II & NY-AC	✗	✓	✗	✓	0.180	F	
9	Cut HQ-Phase II & NY-DC	✗	✓	✓	✗	0.173		
10	Cut Maritimes & NY-AC	✓	✗	✗	✓	0.149		
11	Cut Maritimes & NY-DC	✓	✗	✓	✗	0.143	G	
12	Cut NY-AC & NY-DC	✓	✓	✗	✗	0.109		
13	Cut HQ-Phase II & Maritimes & NY-AC	✗	✗	✗	✓	0.249	D	
14	Cut HQ-Phase II & Maritimes & NY-DC	✗	✗	✓	✗	0.229		
15	Cut HQ-Phase II & NY-AC & NY-DC	✗	✓	✗	✗	0.191		
16	Cut Maritimes & NY-AC & NY-DC	✓	✗	✗	✗	0.157	H	

- There are 8 scenarios (A-H) that can be used for evaluating HQ-Phase II tie benefit contribution.

HQ-Phase II Tie Benefit	A	B	C	D	E	F	G	H	Average
	Current method	LIPA/2002 TB							
Scenarios Compared	1 vs 3	2 vs 16	4 vs 7	12 vs 15	5 vs 8	6 vs 9	10 vs 13	11 vs 14	
LOLE delta (days/year)	0.071	0.156	0.082	0.082	0.076	0.073	0.100	0.086	0.091
Equivalent Tie Benefit (MW)	795	880	660	835	820	805	680	660	767

Evaluation of all possible path “tie benefits”

HQ-Phase II Tie Benefit	A	B	C	D	E	F	G	H	Average
	Current method	LIPA/2002 TB							
Scenarios Compared	1 vs 3	2 vs 16	4 vs 7	12 vs 15	5 vs 8	6 vs 9	10 vs 13	11 vs 14	
LOLE delta (days/year)	0.071	0.156	0.082	0.082	0.076	0.073	0.100	0.086	0.091
Equivalent Tie Benefit (MW)	795	880	660	835	820	805	680	660	767

Maritimes Tie Benefit	A	B	C	D	E	F	G	H	Average
	Current method	LIPA/2002 TB							
Scenarios Compared	1 vs 4	2 vs 15	3 vs 7	12 vs 16	5 vs 10	6 vs 11	8 vs 13	9 vs 14	
LOLE delta (days/year)	0.041	0.122	0.052	0.048	0.045	0.043	0.069	0.055	0.059
Equivalent Tie Benefit (MW)	510	620	385	535	530	520	425	370	487

NY AC Tie Benefit	A	B	C	D	E	F	G	H	Average
	Current method	LIPA/2002 TB							
Scenarios Compared	1 vs 5	2 vs 14	3 vs 8	4 vs 10	6 vs 12	7 vs 13	9 vs 15	11 vs 16	
LOLE delta (days/year)	0.005	0.084	0.009	0.008	0.008	0.026	0.018	0.014	0.021
Equivalent Tie Benefit (MW)	75	390	85	90	120	140	150	130	148

NY DC Tie Benefit	A	B	C	D	E	F	G	H	Average
	Current method	LIPA/2002 TB							
Scenarios Compared	1 vs 6	2 vs 13	3 vs 9	4 vs 11	5 vs 12	7 vs 14	8 vs 15	10 vs 16	
LOLE delta (days/year)	0.001	0.063	0.002	0.002	0.005	0.005	0.011	0.008	0.012
Equivalent Tie Benefit (MW)	15	280	25	25	65	35	90	75	76

Relationship between Evaluation Scenarios (Blue Values show “cumulative tie benefits” along path)

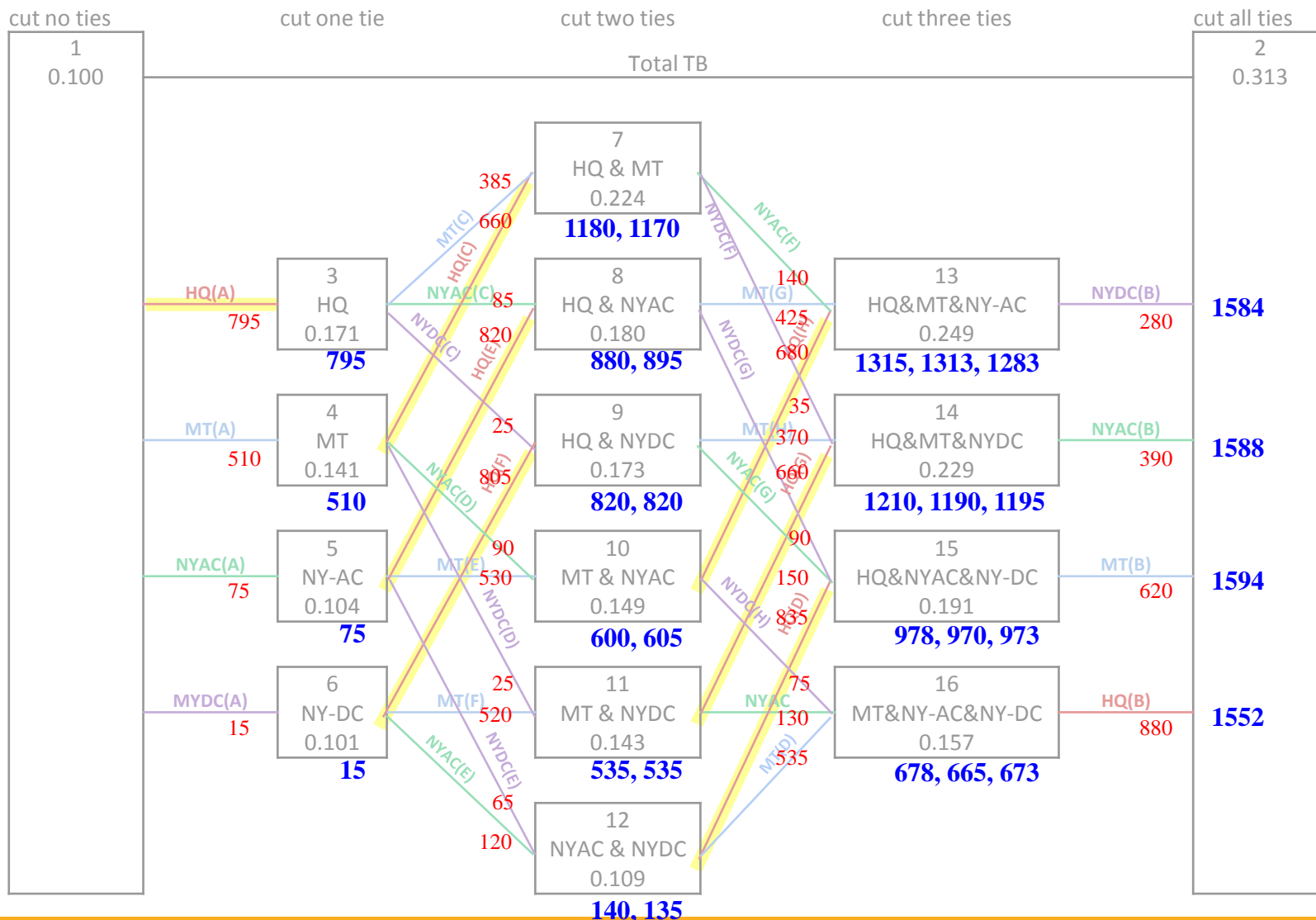

Tie Benefits for Each Tie and For All Ties

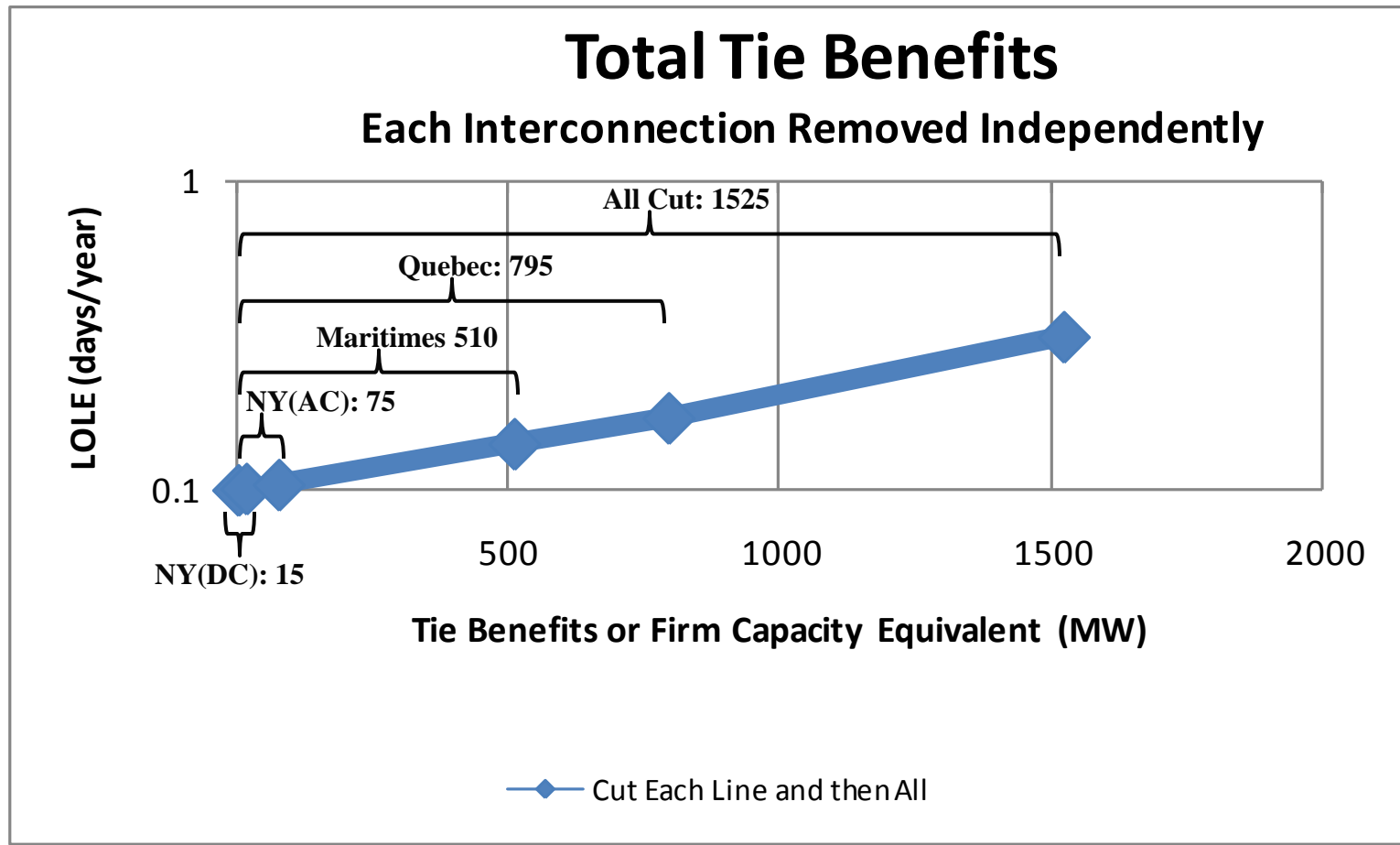

Evaluation Paths for NY(DC)

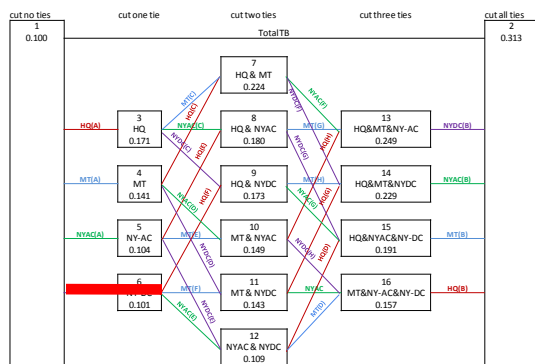

15 MW

Cut First

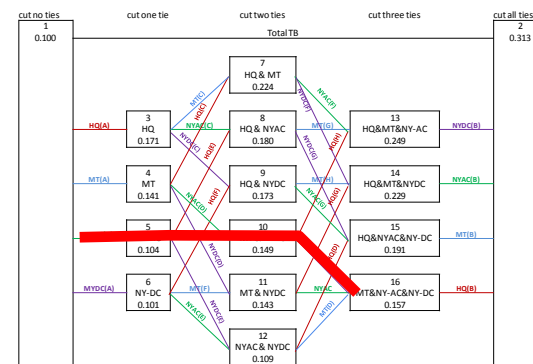

75 MW

Cut Third

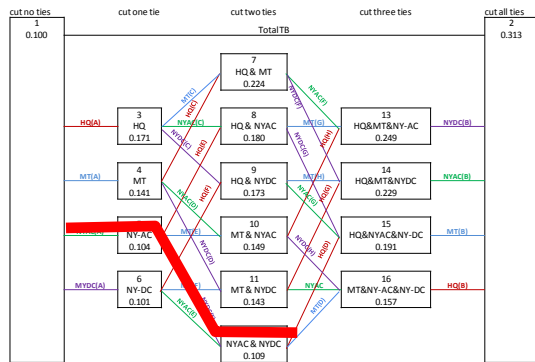

65 MW

Cut Second

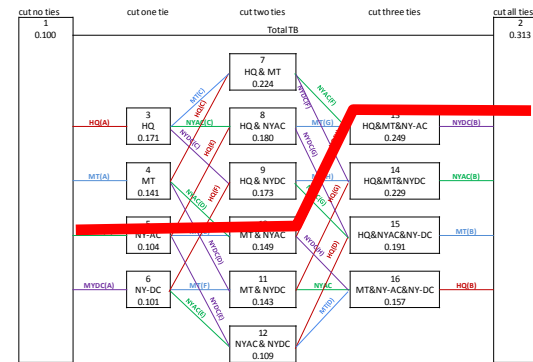

280 MW

Cut Last

Evaluation Paths for NY(AC)

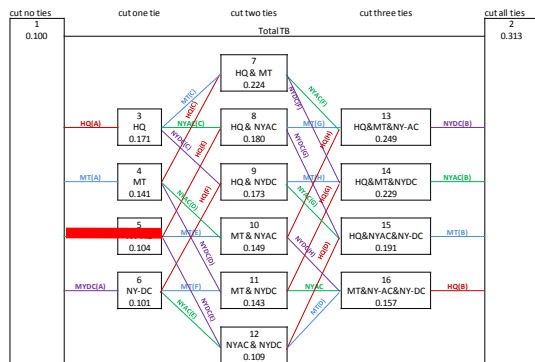

75 MW

Cut First

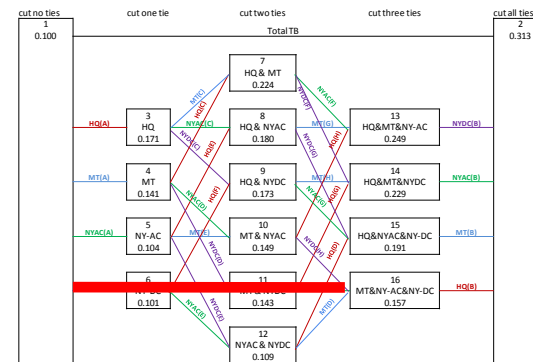

130 MW

Cut Third

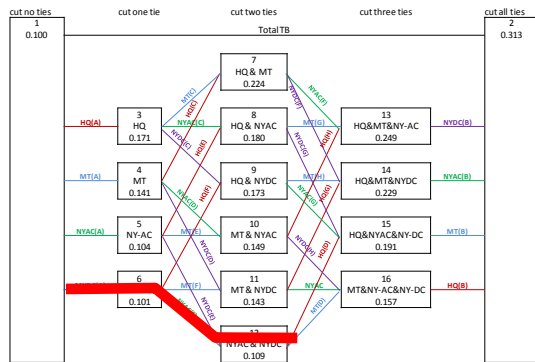

120 MW

Cut Second

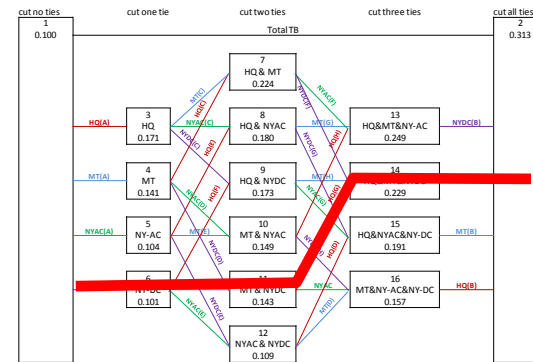

390 MW

Cut Last

NY(AC) increases to 85 MW if cut second

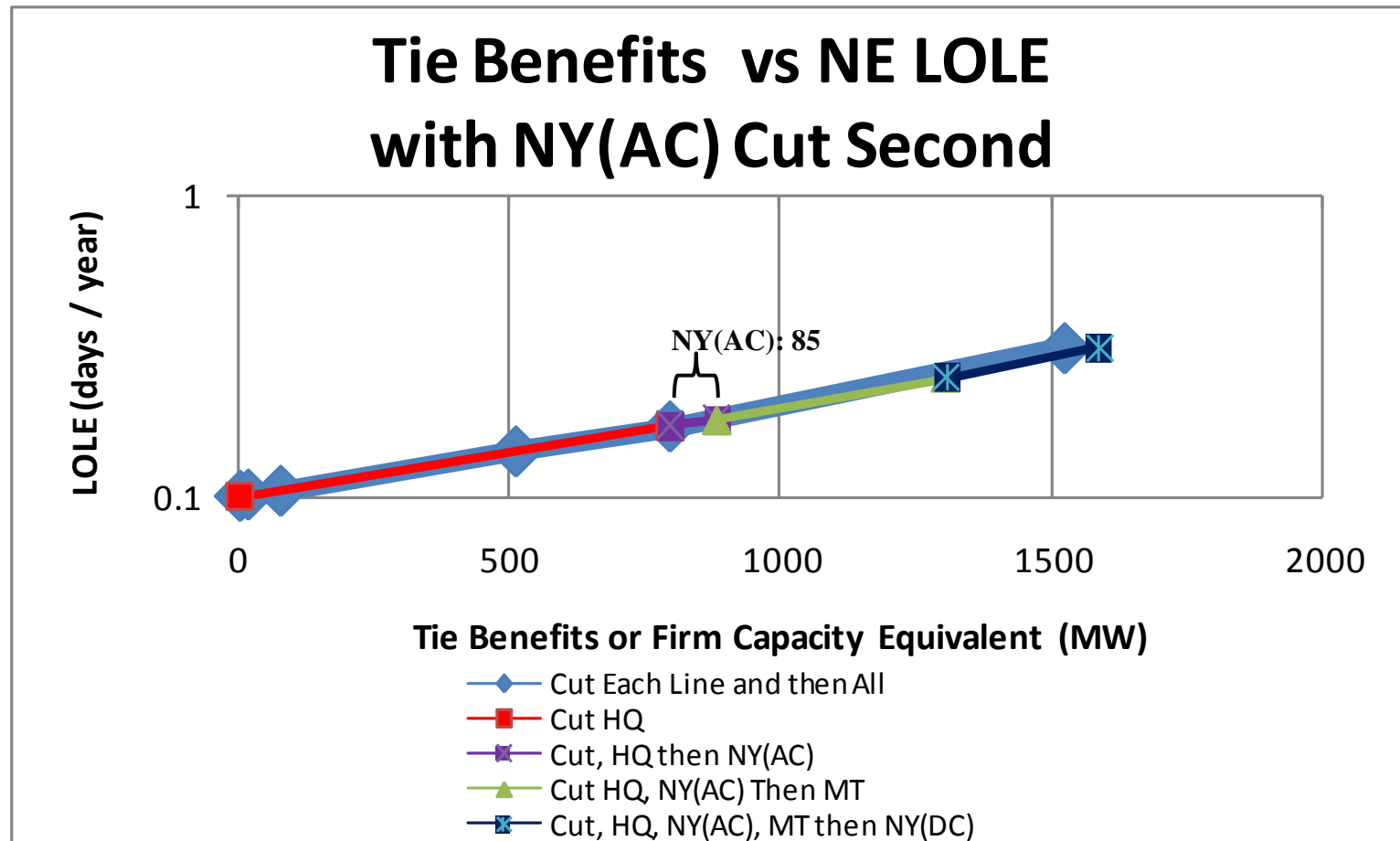

NY(AC) increases to 140 MW if cut third

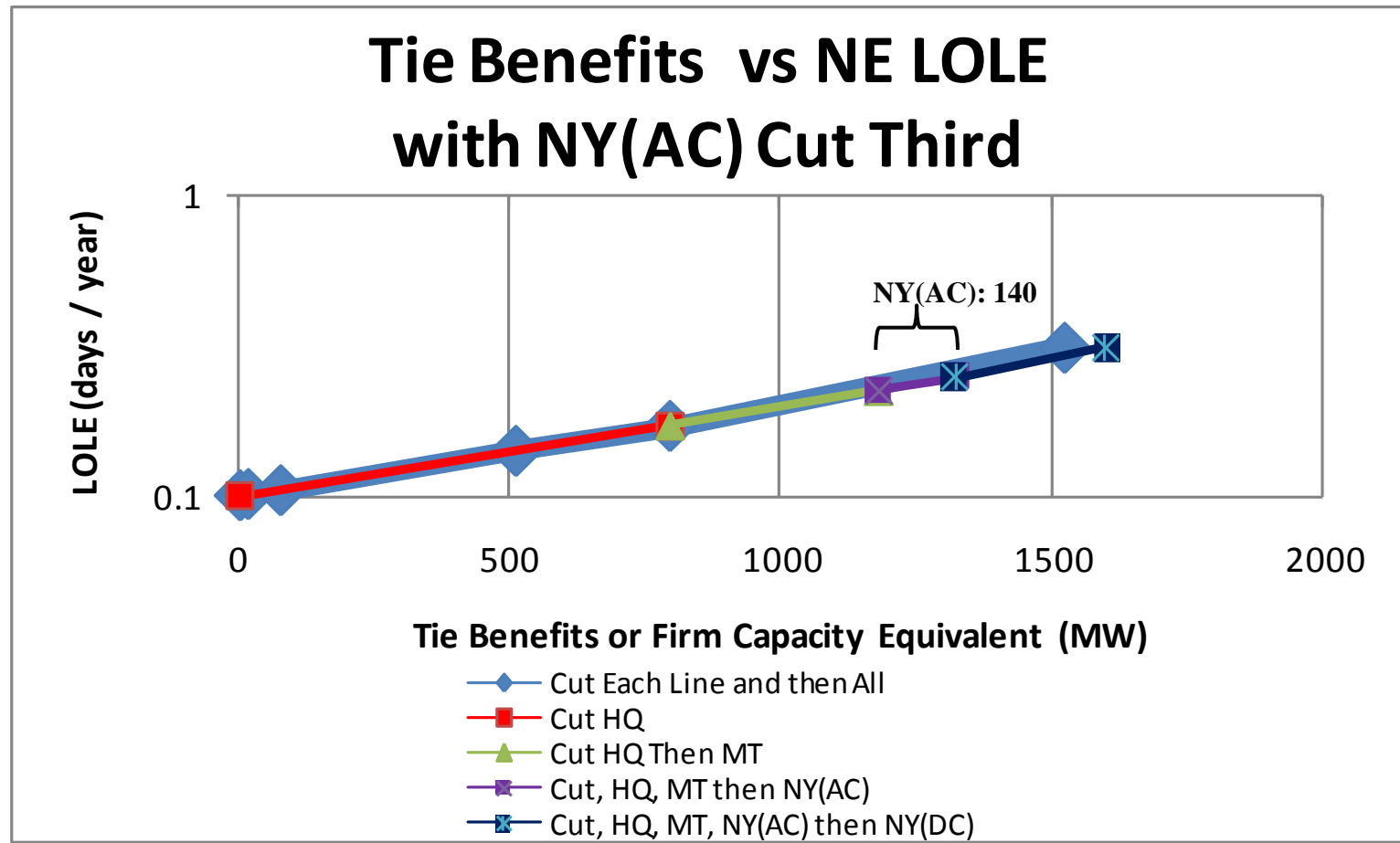

NY(AC) increases to 390 MW if cut fourth

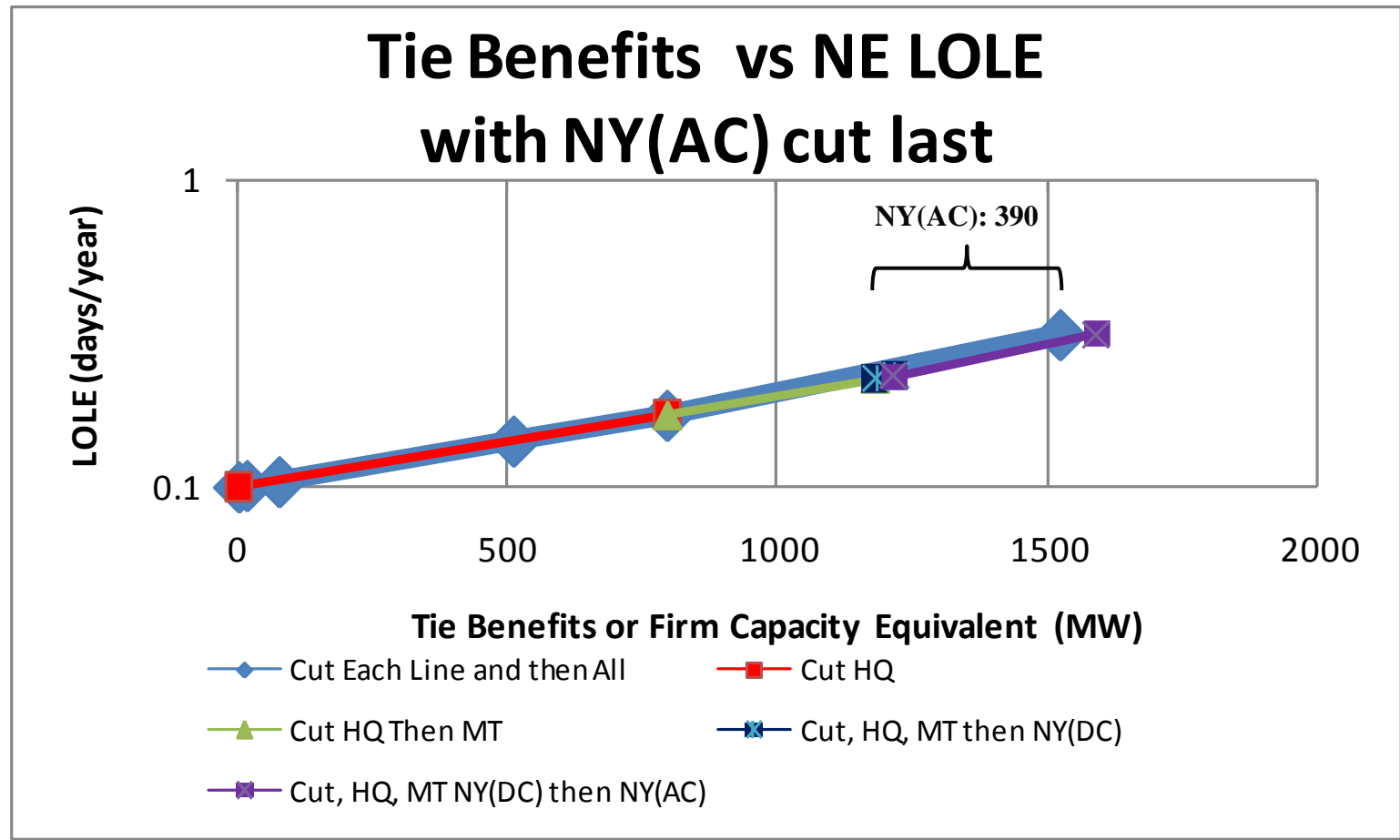

Evaluation Paths for HQ

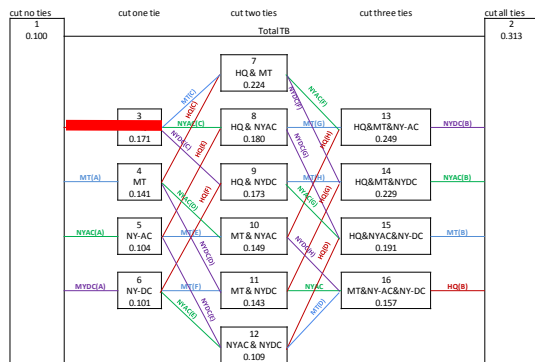

795 MW

Cut First

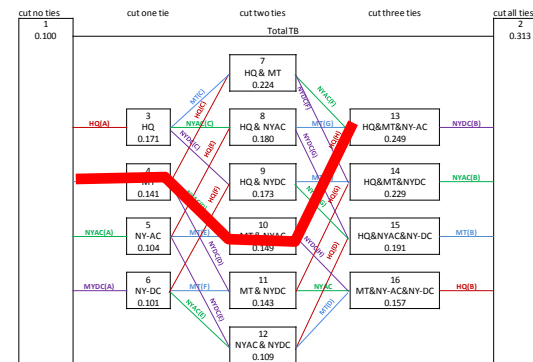

680 MW

Cut Third

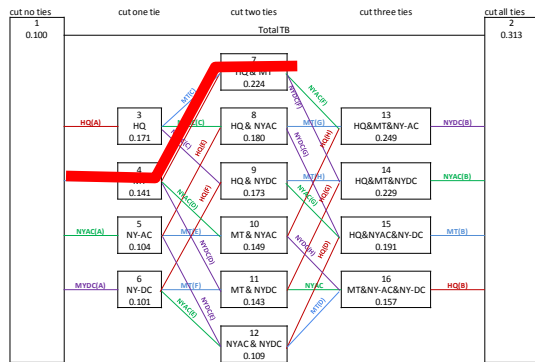

660 MW

Cut Second

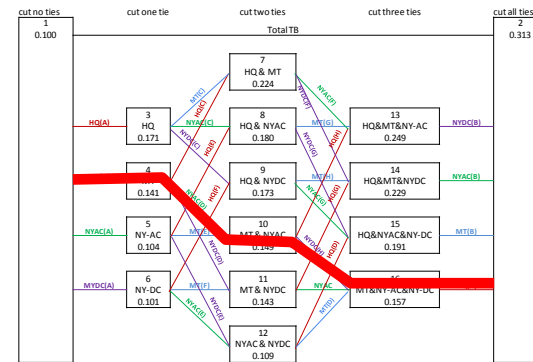

880 MW

Cut Last

Evaluation Paths for MT

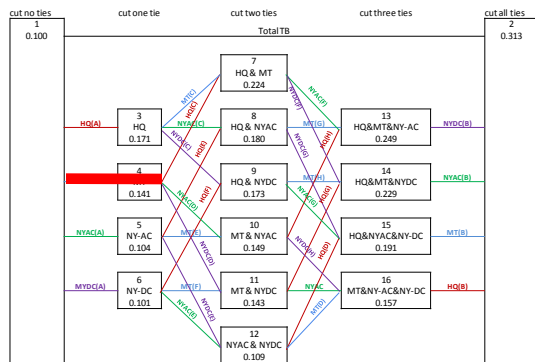

510 MW

Cut First

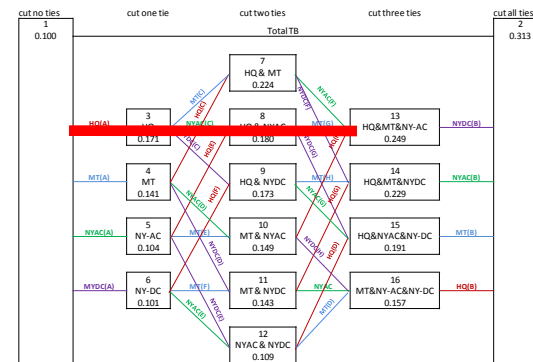

425 MW

Cut Third

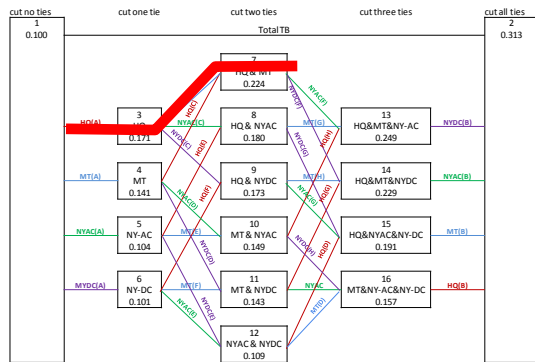

385 MW

Cut Second

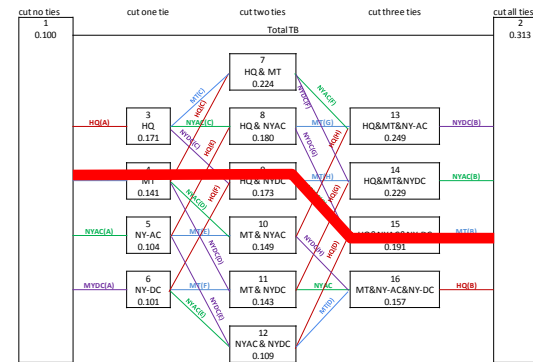

620 MW

Cut Last

Maritimes is 510 MW if Cut First

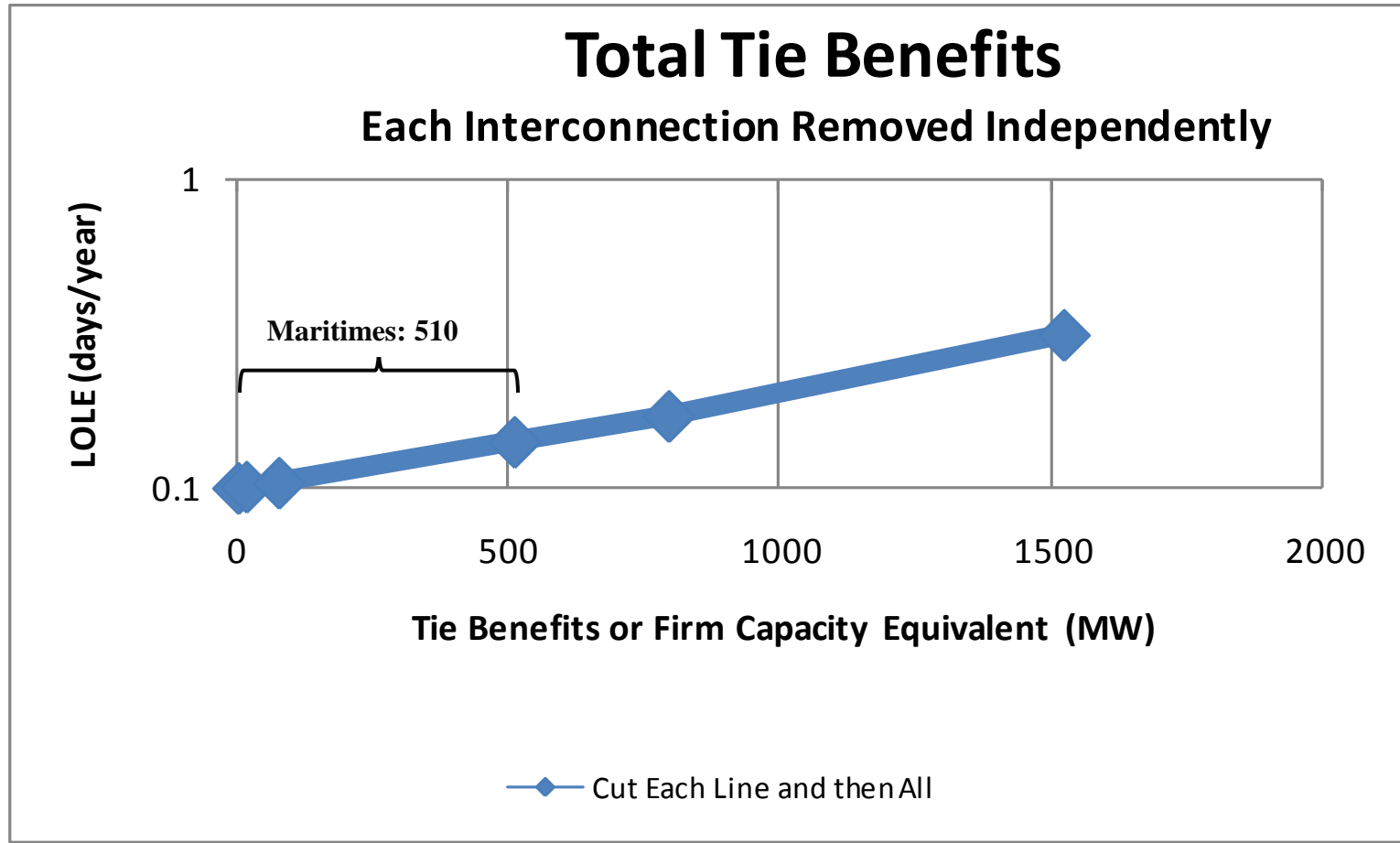

Maritimes Decreases to 385 MW if Cut Second

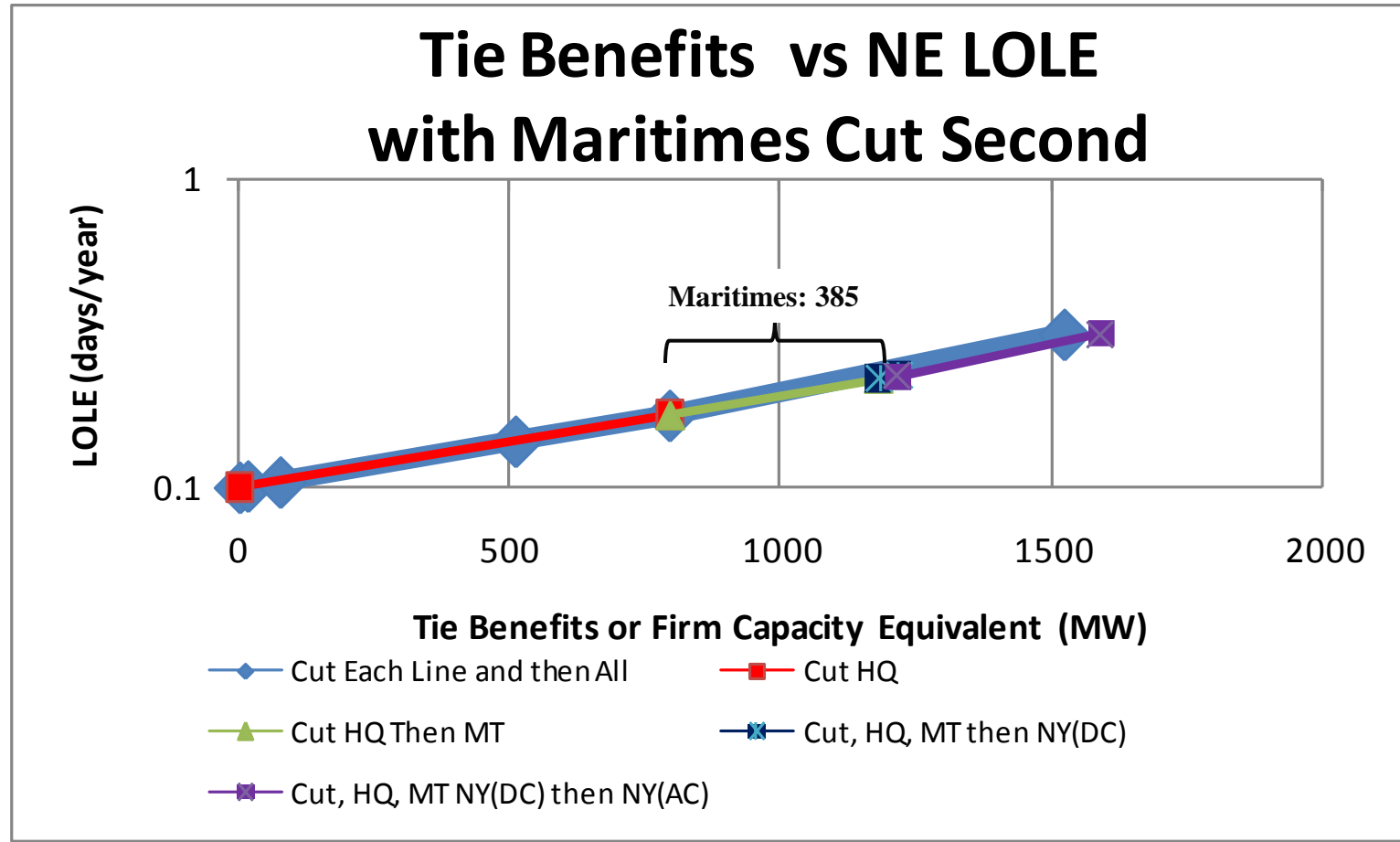

Maritimes Increases to 425 MW if Cut Third

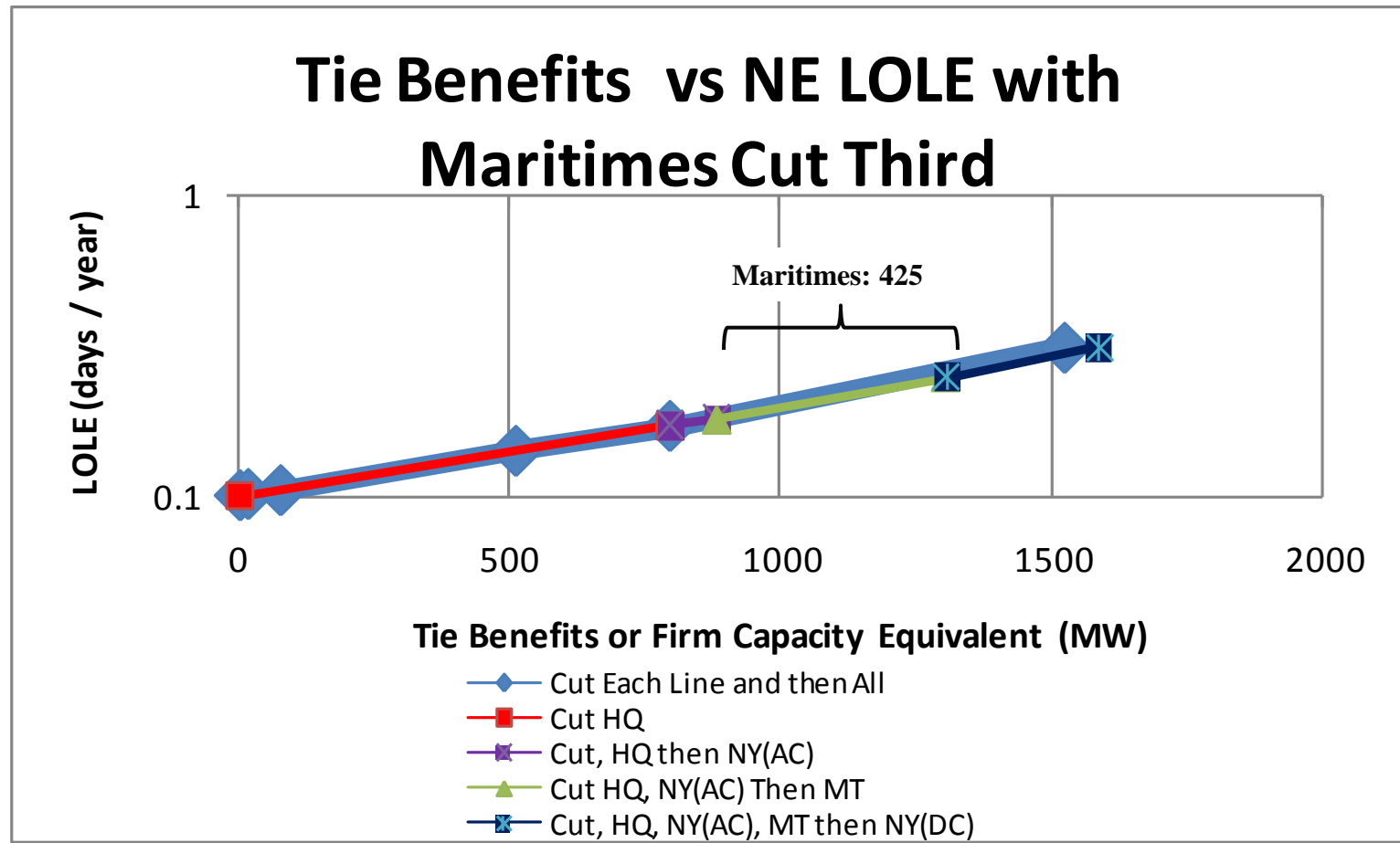

Maritimes Increases to 620 MW if Cut Last

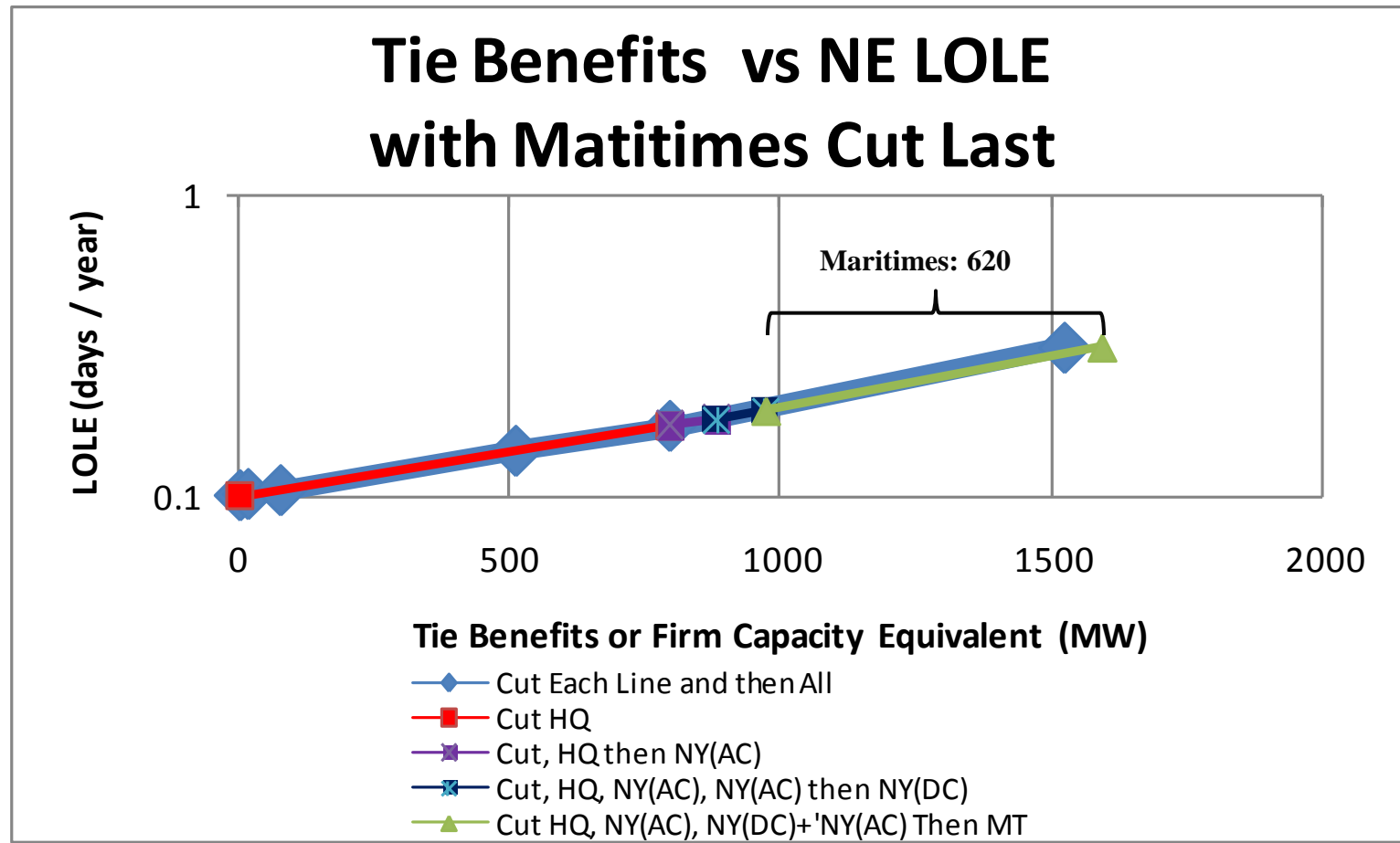

Difference Between Canada / New York

- The results suggest that there is a characteristic difference between Canada and New York
 - New York characteristic suggests increasing tie benefits as it becomes one of the last remaining ties
 - Canada characteristic suggests that:
 - Initially tie benefits decline, then
 - Tie benefits increase as it becomes one of the last remaining ties
 - Difference may be due to the New England to New York Interface
 - New York shares tie benefits from Canada with New England
 - Interface limit from New England to New York may impede tie benefit delivery to New York (2400 MW of transfer capability from Canada and only 1730 MW from New England to Quebec)

